

Για την Ελληνική Έκδοση κάντε κλικ στον πιο κάτω σύνδεσμο:

<http://www.cytanet.com.cy/Services/connectivity/basic/satellite/help/QuickStartGuide-gr-v1.1.pdf>

Satellite Internet

QUICK START GUIDE

(For more advanced features and troubleshooting tips visit

<http://www.cytanet.com.cy/Services/connectivity/basic/satellite/help/manual.pdf>)

A. Service Requirements

- a. Personal Computer with Internet Browser and RJ45 Ethernet card able to support 10 Mbps transfer speed.
- b. Satellite antenna pointed to Sirius 2 satellite at 4,8° East with a diameter of at least 85cm.
- c. Analogue telephone line (PSTN) or digital telephone line (ISDN) with analogue interface, for dial-up connection.

B. Getting started

B.1 F11 Satellite Modem connections

Turn off your computer and connect the cables of the F-11 satellite modem as shown in the figure.

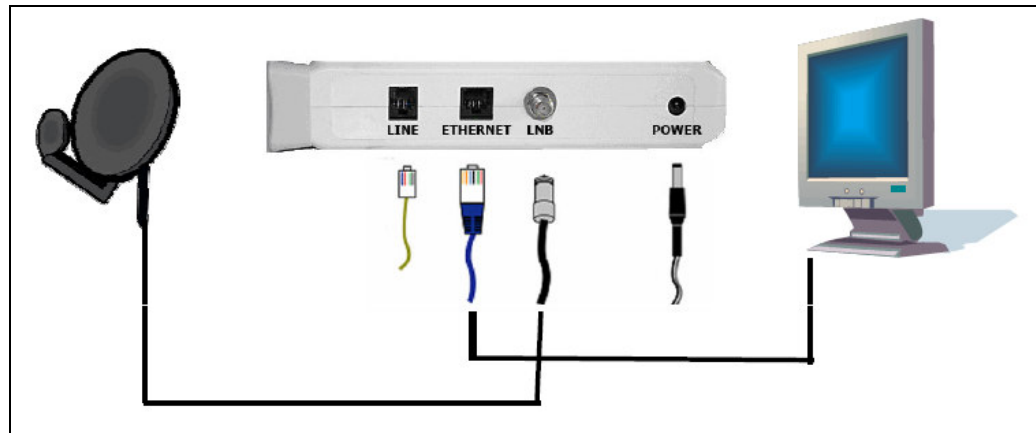

Figure 1: Back side of the F11 satellite modem

- Connect the satellite antenna cable to the socket marked **LNB**.
- Attach the analogue (PSTN) phone line to the F11 satellite modem in the socket marked **LINE**. In case you have an ISDN line, connect one end of the phone cable to the analogue interface of the NT unit (provided by CYTA for the termination of your ISDN line), and the other end to the F11 satellite modem in the socket marked **LINE**.
- Plug one end of the Ethernet network cable, included in the package, into the socket of the F11 satellite modem marked **ETHERNET** and the other end of the cable into the computer's Ethernet socket.

- Connect the power supply unit to the **POWER** socket. Power on your PC.

Note: The power and telephone line cables may require adaptors. In such case, please use the adaptors provided with the modem.

B.2 Setting up the F11 Satellite Modem

- Start the computer and open up the web browser.
- At the address bar, type <http://f11> (or <http://192.168.30.1>) and press **Enter** to open the satellite modem F-11 screen. If you can't communicate with the modem, go to section D - Computer Configuration of the Quick Start Guide. After you are done, type <http://f11> again at the address bar of your web browser and press **Enter**.
- You are now ready to configure the modem. Click the link to the **Connect Page** in the menu (Figure 2) and check the Satellite Signal Quality level meter. If the level meter is green your satellite connection is good and you should proceed to the following section.

In case the level meter is yellow or red, the connection with the satellite is either marginal, or bad. If the level meter is red, (a) check that the parameters in the Advanced Settings Page are set correctly as shown in Figure 3 below (already pre-configured) and (b) check the installation of your dish and connections.

Satellitemodem F-11

Connect Page

The connection is down.

Satellite signal quality

The signal quality level meter shows the quality of your signal. If the meter is red, there is no connection. Yellow represents a possibly intermittent connection and green a stable connection. Once your system is correctly set-up, connection to the satellite will be automatic. You can click the Connect/Disconnect button to manually connect or disconnect the modem link to your ISP.

Transfer statistics

Device	Received	Sent
Ethernet	40926	74936
Satellite	0	N/A

FORSWAY

Figure 2: Connect Page

Satellitemodem F-11

Advanced Settings

Frequency

Symbol Rate

Polarisation

DiSEqC Setting

PIDs

Multicast PIDs

The use of the TellCast software is subject to a license agreement with Telltec Communications bvba (www.telltec.be). Any use without a valid license agreement is forbidden and will be prosecuted.

Proxy server

FORSWAY

Figure 3: Advanced Settings Page

B.2.1 Setup your Dial-up settings

Satellitemodem F-11

Set-up

Important information about passwords

- Upper and lower case letters in the password are distinct.
- A new password has to be entered twice, to catch mistakes the input.

Username: testsat3

Password:

Password (repeat):

Phone Number: 80901600

Wait for dial tone:

Automatic Disconnect when idle after: 20

Language: english

Country: Cyprus

FORSWAY

Figure 4: Setup Page

- Click the link to the **Setup Page** in the menu.
- Type in your **Cytanet username** and **password** (provided to you at the Cytashop with the satellite modem).
- Phone Number: **80901600**.
- Automatic disconnect when idle after: **20 min (factory default)**. The meaning is that you will be disconnected if the modem fails to detect any traffic for twenty minutes. You are advised to set the length of time the system remains connected without any traffic before automatically disconnecting in accordance with your needs. **Please note that there are applications which send traffic to the internet periodically. In this case, idle time might never reach the set time, and consequently, the connection will not be disconnected automatically. In order to avoid such a problem, you are always advised to manually disconnect your internet session (section B.2.3).**
- Country: **Cyprus**.

B.2.2 Setup your Proxy Username and Password for the Satellite Connection

- Click the link to the **Proxy setup** in the menu.
- Enter your **proxy username** and **proxy password**. (provided to you at the Cytashop with the satellite modem).

Satelit modem F-11

Connect Page

Set-up

Advanced Settings

Updates & Support

Exclusion List

Network set-up

Proxy set-up

Tellitec page

Proxy setup

Important information about passwords

- Upper and lower case letters in the password are distinct.
- A new password has to be entered twice, to catch mistakes the input.

Username

Password

Password (repeat)

Save

FORSWAY

Figure 5: Proxy setup

B.2.3 Connect/disconnect to the Internet

Go to the Connect Page (Figure 6) and click the **Connect** button to connect to the Internet. It may take up to 20 seconds to obtain a connection. See Figure 6 for an illustration of the connection process.

Satelit modem F-11

Connect Page

The connection is down.

Satellite signal quality

The signal quality level meter shows the quality of your signal. If the meter is red, there is no connection. Yellow represents a possibly intermittent connection and green a stable connection. Once your system is correctly set-up, connection to the satellite will be automatic. You can click the Connect/Disconnect button to manually connect or disconnect the modem link to your ISP.

Transfer statistics

Device	Received	Sent
Ethernet	40926	74936
Satellite	0	N/A

FORSWAY

Figure 6: Modem connecting

- You can also use this page **to terminate** your internet session manually.

C. Traffic Volume Monitoring

You can always check the traffic volume downloaded to your computer by visiting the page <https://rbcis.astra-net.com/cyta/>. Use your **proxy username** and **password** to access the page.

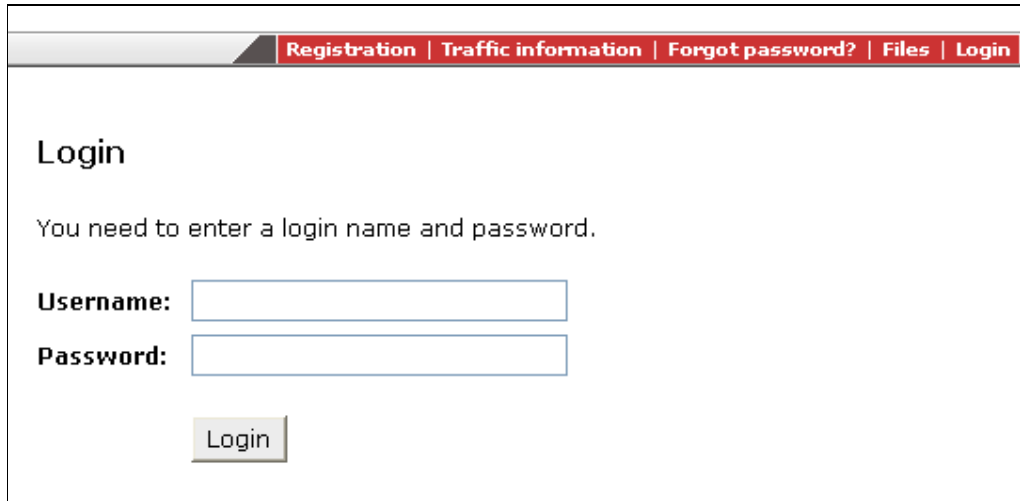

Registration | Traffic information | Forgot password? | Files | Login

Login

You need to enter a login name and password.

Username:

Password:

Login

Figure 7: User login page

Please note that the reception speed is reduced according to the volume of information that is downloaded in intervals of thirty (30) days. In other words, on average heavy users who download a lot of content should normally expect lower reception speeds compared to light users.

D. Computer Configuration

The computer must be configured to receive an IP address via DHCP. The rest of the configuration is automatic. You do probably already have DHCP enabled and can continue to next section, but if you can't communicate with the modem this can be a good thing to check.

The explanation below is a guide on how to enable DHCP in Windows XP. Other operating systems have a similar approach.

1. Begin by opening the Windows XP Control Panel. Click the Start button, and then select Control Panel.
2. Click on the link labelled Network Connections to see a list of your network connections.
3. Right-click on the icon labelled **Local Area Connection** and select **Properties**. (Note: If you do not see this icon, your Network Interface Card may be improperly installed.) The dialog box in figure 8 should appear.
4. Select **Internet Protocol (TCP/IP)** and click on **Properties**. The dialog box in figure 9 should appear.
5. Select the Obtain an IP address automatically and Obtain DNS server address automatically options.
6. Press **OK/Close** in both dialog boxes. DHCP is now enabled.

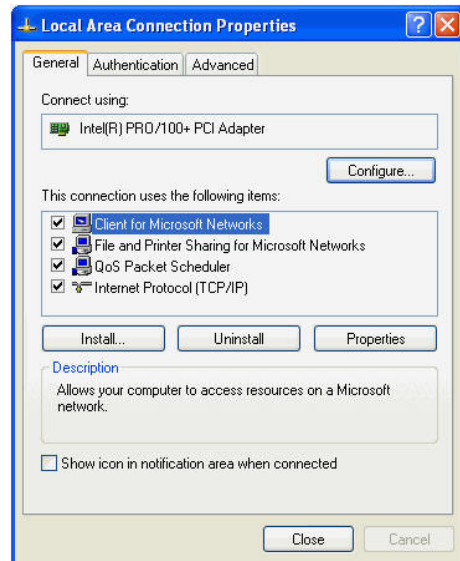

Figure 8: LAN properties

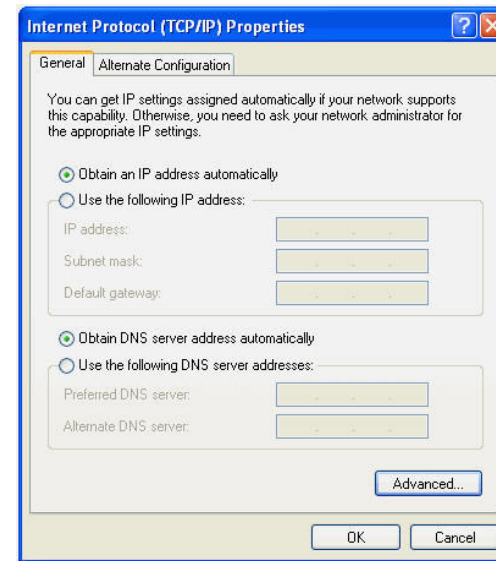

Figure 9: TCP/IP properties

E. Troubleshooting

Modem Indicator Lights

There are three indicators on the front side of the modem. These indicate the following:

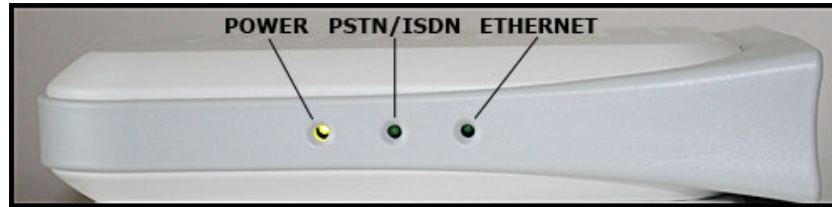

Figure 10: Front side of the satellite modem

LED Functionality			
LED	Power	PSTN/ISDN	Ethernet
<i>Flashing green</i>	Modem is booting	-	Data transfer between modem and computer
<i>Steady green</i>	Normal operation	Dial-up internet connection is active	Connection to the computer is established

- Make sure that all three leds are green.
- If the PSTN/ISDN led is off, check your telephone line and verify that your Cytanet username and password are correct.
- If the Ethernet led is off, check the following:
 - check that your RJ45 Ethernet card is configured for DHCP- see Section D.
 - check that your RJ45 Ethernet card supports 10Mbps transfer speed.
 - check the Ethernet cable connections.